

Type 757 and 779 Series GRANGER™ Electrically Steerable, Log-Periodic Antennas

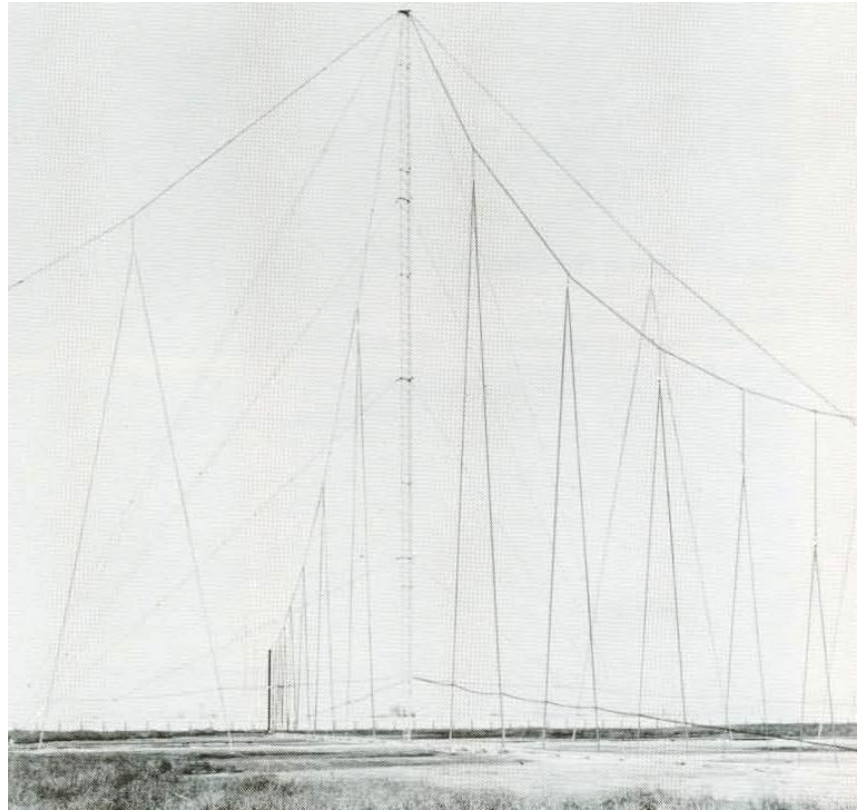

- **3-30 MHz Frequency Range**
- **Up to 20 kW Average, 40 kW Peak Power Rating**
- **Vertical Polarization Compatible with Omnidirectional Antennas**
- **2.0:1 Maximum VSWR**
- **Medium-to-Long Range Communications**
- **High Gain: 11+ dBi**
- **No Active Devices to Cause Overload IM or High Noise Levels When Used in Receive Mode**
- **Resistant to Harsh Environments**
- **Sector Steerable**



General Description

Antennas in the 757 and 779 Series consist of four vertically-polarized, log-periodic antenna curtains. Each curtain operates independently of the other three. The curtains, supported by a common central tower, radiate a rosette pattern of overlapping sectors for full coverage in the azimuth plane. Elevation plane radiation patterns of the two series are shown on page 3.

Series 757 antennas are vertical monopoles that use a ground screen to maintain impedance and 10 dBi gain. Nominal azimuth beamwidth is 110° and elevation beamwidth is 30°. Gain for the 779 Series is rated at greater than 11 dBi, over perfect ground. Antennas in this series are center-driven transposed dipoles, which do not need a ground screen over normal ground. Nominal azimuth beamwidth is 125°±25° and elevation beamwidth is 22°. Both the 757 and 779 antennas maintain their impedance characteristics over a broad band of

frequencies. In the case of the 779 Series, with its dipole arrangement, constant impedance is achieved by incorporating baluns which are carefully matched to the antenna. The unbalanced feed system of the Type 757 is matched to 50 ohm coaxial line by a special transformer. These antennas, which are light structures with extraordinary strength and resiliency, have operated for long periods in harsh environments all over the world.

Applications

These two series of high-gain, log-periodic antennas provide 360° azimuth coverage for efficient, steerable long-haul performance in the 3-30 MHz sector of the radio spectrum.

Standard types are available in various frequency ranges for applications such as airport communications, transmission between ship and shore installations, secure communications, signal monitoring, ionospheric sounder transmission or reception and general purpose HF radio communications. Every array provides a minimum of four transmit/receive operations with a free choice of sector coverage. Four types with receive-only functions are offered in these series. Each antenna system can handle numerous “stations” when multicouplers are used.

Airport Communications. One of the most important applications of Type

757 and 779 antennas is airport communications, where they are often used in conjunction with a compact, omnidirectional antenna. The use of multicouplers with these antennas allows a number of operating positions to share the advantages of the directional antenna system.

General Purpose and Back-Up. In this application, the 757 or 779 antennas either replace an existing point-to-point antenna or meet a special communications requirement for which the station has no specific antenna available. The broad elevation coverage of these antennas allows their use on any medium-to-long-distance circuit. A single antenna can provide service on a number of different communication paths sequentially.

With Ionospheric Sounders. The 757 and 779 antennas have proved particularly useful in point-to-point ionospheric network sounding. Their independent sector coverage allows sequential or simultaneous transmission on all four curtains to widely dispersed receiving stations. (During simultaneous transmission, the sounder can operate on one curtain while other transmitters use remaining curtains.)

Features

Economical Performance. All of the antennas in the 757 and 779 Series give quality performance at significant savings. Because of its configuration, one antenna array handles several separate transmit/receive operations. These arrays occupy only a small fraction of the land usually required

for high-gain antennas with their frequency ranges. Field-proven design characteristics result in a minimum of downtime, and the materials used have been chosen for their reliability and low maintenance requirements.

The 779 Series is especially suitable for locations at which site improvement is difficult or impossible, since no ground screen is needed.

Shipping and Installation. The central tower which supports a 757 and 779 antenna is shipped unassembled so that it occupies minimal shipping volume. The knockdown tower sections are easy to assemble in the field. All parts are supplied, with the exception of the front poles which are Douglas fir, normally procured locally. Antennas can be erected without a crane, using an erection fixture available as an option. Siting instructions are included with all antennas. In addition, ASC offers field engineering services for siting and installing antennas. When comprehensive service is desired, ASC will undertake all responsibility for providing an effective antenna system, including propagation analysis, antenna specifications, manufacturing, installation and field tests.

Multicoupling Capability. A multicoupler permits two transmitters (or receivers) to operate through a single antenna, one on a low channel, the other on a higher one. For receiving applications, a multicoupler is available with 2, 4 or 8 output ports. Because the unit is passive, overloading and distortion

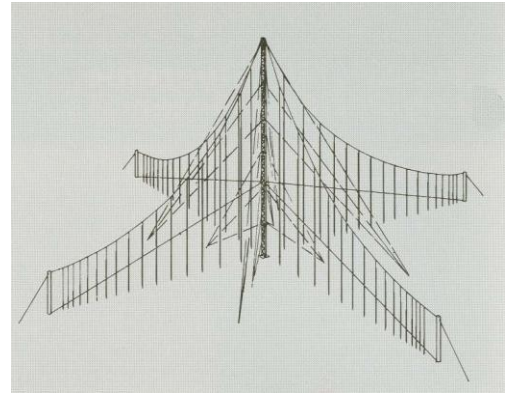

are eliminated. Receiving multicouplers are hermetically sealed for long, trouble-free service.

Omnidirectional. The characteristics of omnidirectional antennas enable them to search quickly through an assigned range and locate a signal. Used with 757 and 779 Series antenna arrays, they can then turn communications over to the log-periodic antenna and return to the

Characteristics

Type	Sector coverage, log-periodic
Frequency Range, MHz	3-32 MHz
Power Rating, kW	Type 779-up to 20 average, 40 peak
Polarization	Type 757- up to average, 20 peak
Input Impedance, ohms	Vertical
VSWR	50, 300
	2.0:1 maximum
Gain over perfect ground, dBi	10.5 nominal- Type 757 12 nominal –Type 779
Azimuth Plane Radiation Pattern	See page 3
Elevation Plane Radiation Pattern	See page 3
Wind Survival Rating, mph (km/h)	
Without Ice	120 (190)
With 0.5 in (12mm) Radial Ice	100 (160)

Elevation Plane Radiation Patterns

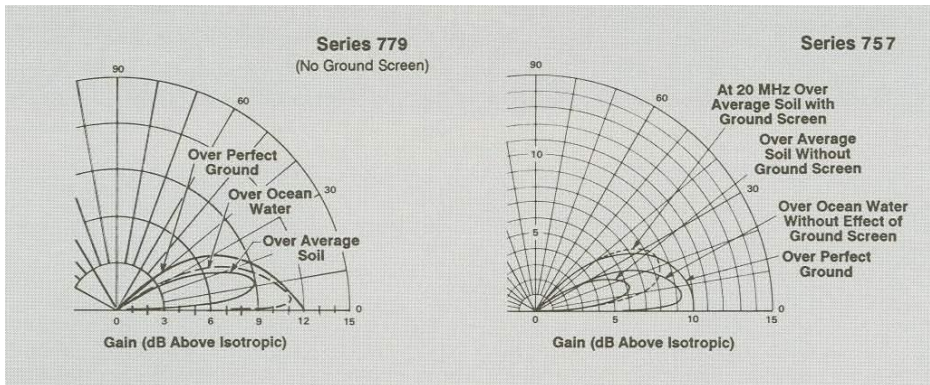

Antenna Dimensions

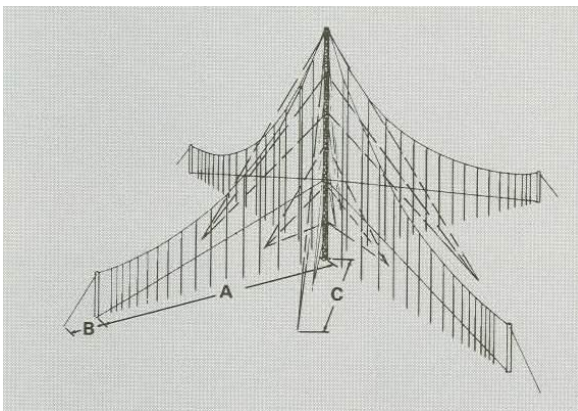

Azimuth Plane Radiation Patterns

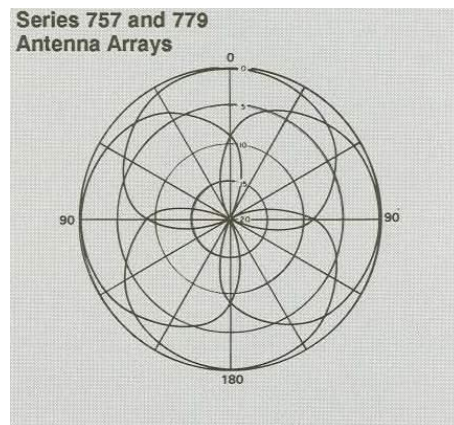

Dimensions

Type Number	Dimension A ft (m)	Dimension B ft (m)	Dimension C ft (m)	Tower Height ft (m)	Pole Length Ft (m)	Front Pole Height Above Ground ft (m)	Ground Screen Area ft (m)
757-1K	210 (64)	24 (7.3)	110 (33.6)	140 (42.6)	35 (10.7)	26 (7.9)	620 x 620 (189 x 189)
757-2K	210 (64)	24 (7.3)	110 (33.6)	140 (42.6)	35 (10.7)	26 (7.9)	620 x 620 (189 x 189)
757-3K	150 (45.7)	17 (5.2)	80 (24.4)	100 (30.5)	25 (7.6)	19 (5.8)	500 x 500 (153 x 153)
757-4K	150 (45.7)	17 (5.2)	80 (24.4)	100 (30.5)	25 (7.6)	19 (5.8)	500 x 500 (153 x 153)
779-1K	255 (77.8)	51 (15.6)	185 (56.4)	221 (67.4)	50 (15.3)	44 (13.4)	
779-2K	255 (77.8)	51 (15.6)	185 (56.4)	221 (67.4)	50 (15.3)	44 (13.4)	
779-3K	255 (77.8)	51 (15.6)	185 (56.4)	221 (67.4)	50 (15.3)	44 (13.4)	
779-4K	255 (77.8)	51 (15.6)	185 (56.4)	221 (67.4)	50 (15.3)	44 (13.4)	
779-6K	193 (58.9)	37 (11.3)	141 (43.0)	171 (52.2)	40 (12.2)	35 (10.7)	
779-7K	193 (58.9)	37 (11.3)	141 (43.0)	171 (52.2)	40 (12.2)	35 (10.7)	
779-8K	193 (58.9)	37 (11.3)	141 (43.0)	171 (52.2)	40 (12.2)	35 (10.7)	
779-9K	193 (58.9)	37 (11.3)	141 (43.0)	171 (52.2)	40 (12.2)	35 (10.7)	
779-14K	255 (77.8)	51 (15.6)	185 (56.4)	221 (67.4)	50 (15.3)	44 (13.4)	
779-15K	193 (58.9)	37 (11.3)	141 (43.0)	171 (52.2)	40 (12.2)	35 (10.7)	

Ordering Information

Type Number	Frequency Range MHz	Power Rating kW Average	Peak	Input Impedance ohms	Input Connector
757-1K	3-32	Receive Only			N Female
757-2K	3-32	10	20	50	1-5/8 in coaxial, Female
757-3K	4-32	Receive Only			N Female
757-4K	4-32	10	20	50	1-5/8 in coaxial, Female
779-1K	3.5-32	20	40	300	Open lines
779-2K	3.5-32	Receive Only			N Female
779-3K	3.5-32	10	20	50	1-5/8 in coaxial, Female
779-4K	3.5-32	20	40	50	1-5/8 in coaxial, Female
779-6K	4.6-32	20	40	300	Open lines
779-7K	4.6-32	Receive Only			N Female
779-8K	4.6-32	10	20	50	1-5/8 in coaxial, Female
779-9K	4.6-32	20	40	50	1-5/8 in coaxial, Female
779-14K	3.5-32	2.5	30	50	N Female
779-15K	4.6-32	2.5	30	50	N Female

Accessories

The following accessories are available for ease of installation and maintenance: tower lighting kit, erection kit, paint kit, tool kit, lightning rod kit, anti-climbing kit and spares kit.

